



QM lighting

QM-01026

B22 1W



Add: 3F, HuShanRoad, No. 13, Daguangkan Industrial Zone, Bantian, LonggangDistrict, Shenzhen,

Guangdong, China

Tel: 86-755-84714721 Fax: 86-755-84714707

E-mail: qm@qmlighting.com

Website: www.qmlighting.com

Copyright© 2008 QM Lighting, Inc. All rights reserved.

version : 1.0



QM lighting

Dimensions

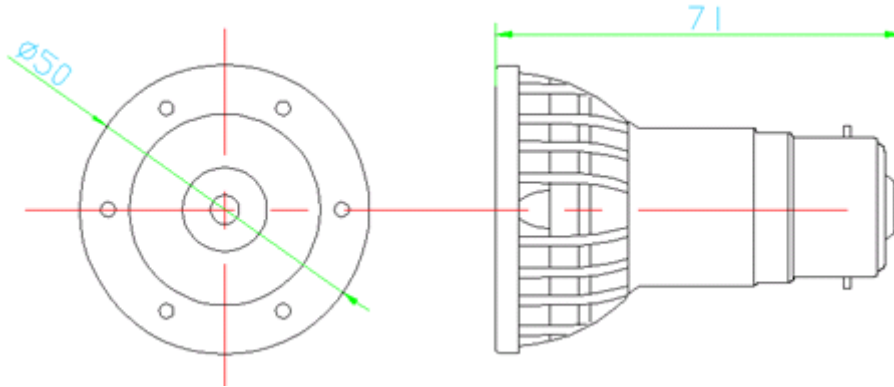

Unit: mm

Tolerance: ± 2.5 mm

Specifications

- BULB TYPE: 1W B22 LED Bulb
- BASE TYPE: B22
- INPUT VOLTAGE: AC85-260V with reversed polarity protect
- INPUT POWER: 1.3W
- OUTPUT POWER: 1W
- TOTAL LENGTH: 71mm
- BEAM ANGLE: 19.8degrees
- REFLECTOR EFFICIENCY: 85%
- LIGHT SOURCE: 1W high power LED
- LED OUTPUT CURRENT: 320mA
- BODY TEMPERATURE: $< 55^{\circ}\text{C}$
- LED WORKING TEMPERATURE: $-20^{\circ}\text{C} \sim 50^{\circ}\text{C}$
- FULL RANGE OF COLORS: cool white, warm white, blue, green ,red,yellow ,RGB
- NET WEIGHT: 78g
- ALUMINIUM HOUSING
- NO UV OR IR RADIATION
- SAFETY ASSURANCE: CE&RoHS

Illuminance and Beam Angles

part no.	LED Brand	Color	wavelength/CCT (nm/K)	Luminous Flux (LM)	Power Factor	Color-rendering index	Light Effect (lm/W)
QM-01026-001	Cree	cool white	5000-7000K	63.9	1.7	70 ~ 75	37.4
QM-01026-002		Nature white	3500-5000K	48.5	1.6	80 ~ 85	29.4
QM-01026-003		warm white	2700-3500K	48.5	1.6	80 ~ 85	29.4

Add: 3F, HuShanRoad, No. 13, Daguangkan Industrial Zone, Bantian, LonggangDistrict, Shenzhen,

Guangdong, China

Tel: 86-755-84714721 Fax: 86-755-84714707

E-mail: qm@qmlighting.com

Website: www.qmlighting.com

Copyright© 2008 QM Lighting, Inc. All rights reserved.

version : 1.0



QM lighting

cool white

CIE Parameter:

Coordinate: x=0.3234, y=0.3492	CCT: Tc=5886 K	Purity=3.3%		
u=0.1977, v=0.3202	Main Wave=514.4nm	Peak Wave=450.0nm		
Half Width=32.7nm	Red Ratio=13.8%	Chromatism SDCM=3.3		
Color rendering property :Ra=75.1				
R1=71	R2=80	R3=86	R4=74	R5=72
R6=73	R7=85	R8=60	R9=-26	R10=52
R11=69	R12=49	R13=73	R14=92	R15=65

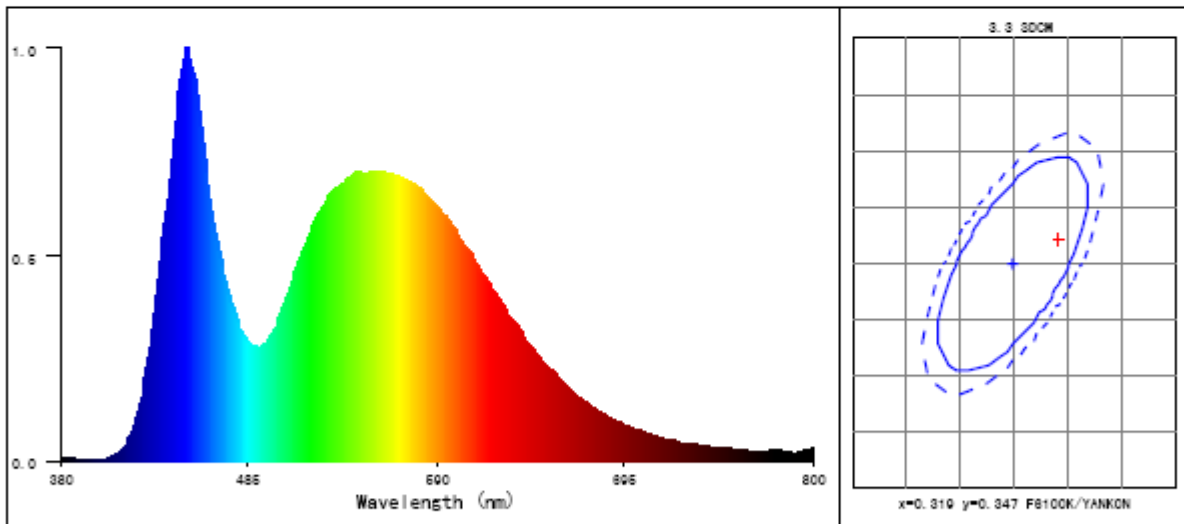

Other parameters:

Flux: $\Phi=63.9$ Lm	Efficiency: Effi=37.4 Lm/W	Stability: %=-5.3 %	THD= 0.0%
Voltage: U=220.2 V	Current: I=0.018 A	Power: P=1.7 W	Power factor :PF=0.439

Add: 3F, HuShanRoad, No. 13, Daguangkan Industrial Zone, Bantian, LonggangDistrict, Shenzhen,

Guangdong, China

Tel: 86-755-84714721 Fax: 86-755-84714707

E-mail: qm@qmlighting.com

Website: www.qmlighting.com

Copyright© 2008 QM Lighting, Inc. All rights reserved.

version : 1.0



QM lighting

warm white

CIE Parameter:

Coordinate: $x=0.4576, y=0.4117$	OCT: $T_c=2740\text{ K}$	Purity=60.9%		
$u=0.2606, v=0.3516$	Main Wave=583.8nm	Peak Wave=610.0nm		
Half Width=147.3nm	Red Ratio=26.4%	Chromatism SDCM=0.8		
Color rendering property : $R_a=82.0$				
R1=81	R2=88	R3=92	R4=80	R5=79
R6=82	R7=88	R8=67	R9=25	R10=69
R11=76	R12=62	R13=82	R14=94	R15=77

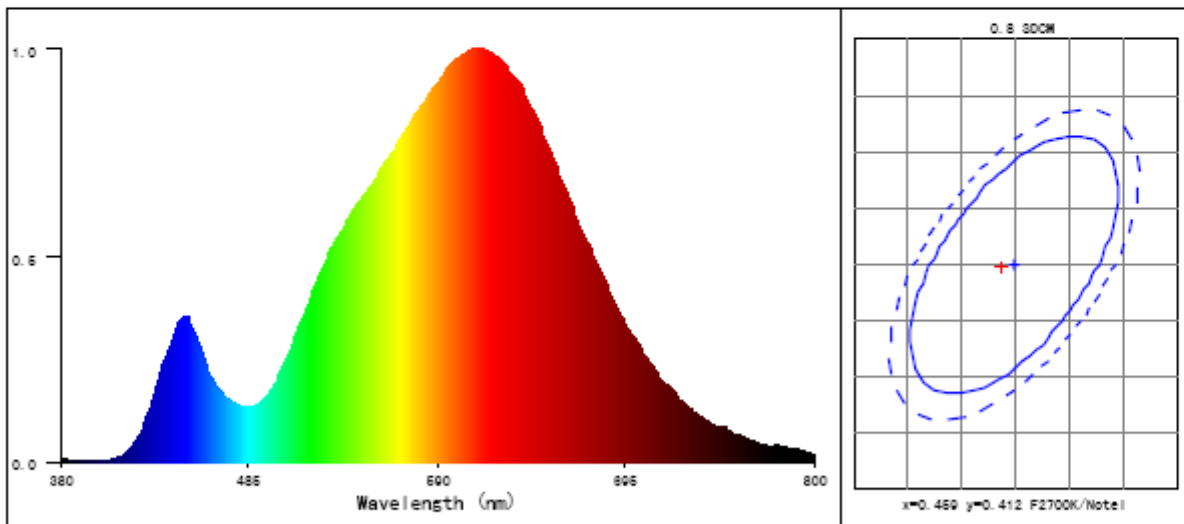

Other parameters:

Flux: $\Phi=48.5\text{ Lm}$	Efficiency: $\text{Effi}=29.4\text{ Lm/W}$	Stability: $\%=-6.1\%$	THD= 0.0%
Voltage: $U=220.2\text{ V}$	Current: $I=0.017\text{ A}$	Power: $P=1.6\text{ W}$	Power factor: $\text{PF}=0.429$

Add: 3F, HuShanRoad, No. 13, Daguangkan Industrial Zone, Bantian, LonggangDistrict, Shenzhen,

Guangdong, China

Tel: 86-755-84714721 Fax: 86-755-84714707

E-mail: qm@qmlighting.com

Website: www.qmlighting.com

Copyright© 2008 QM Lighting, Inc. All rights reserved.

version : 1.0



QM lighting

25° cool white

Photometric Results

Lumens

Angle of maximum intensity: C: 0.0 G: 0.9

Efficiency

Half Peak Side Left: -6.3 Right: 4.5

Central Intensity: 803.500 cd

Beam Angle(10%): Left: -13.5 Right: 12.6

Maximum Intensity: 814.900 cd

Light Distribution Curve C0/C180

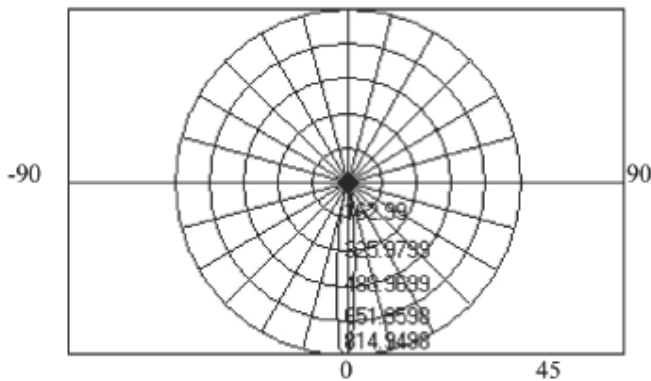

Light Distribution Curve C90/C270

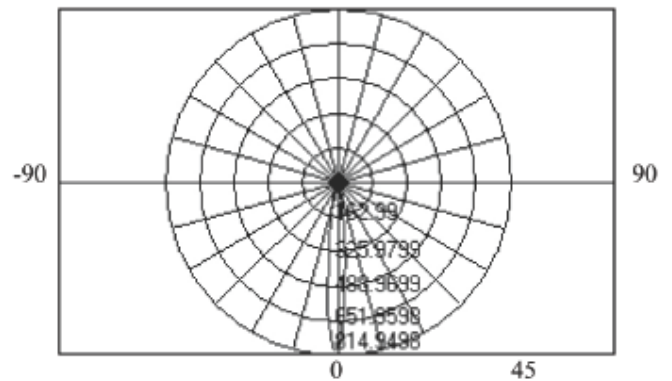

H[m]	Diameter[m]	Illuminance[lx]
0.60	0.11	2232.0
1.20	0.23	558.0
1.80	0.34	248.0
2.40	0.45	139.5
3.00	0.57	89.3

Half peak angle: 2 x 5.4° @ C0-C180

H[m]	Diameter[m]	Illuminance[lx]
0.60	0.11	2169.4
1.20	0.23	542.3
1.80	0.34	241.0
2.40	0.45	135.6
3.00	0.57	86.8

Half peak angle: 2 x 5.4° @ C90-C270

Add: 3F, HuShanRoad, No. 13, Daguangkan Industrial Zone, Bantian, LonggangDistrict, Shenzhen,

Guangdong, China

Tel: 86-755-84714721 Fax: 86-755-84714707

E-mail: qm@qmlighting.com

Website: www.qmlighting.com

Copyright© 2008 QM Lighting, Inc. All rights reserved.

version : 1.0



QM lighting

25° warm white

Photometric Results

Lumens :

Efficiency

Central Intensity: 591.100 cd

Maximum Intensity: 610.100 cd

Angle of maximum intensity: C: 170.0 G: 1.8

Half Peak Side Left: -6.3 Right: 3.6

Beam Angle(10%): Left: -12.6 Right: 12.6

Light Distribution Curve C0/C180

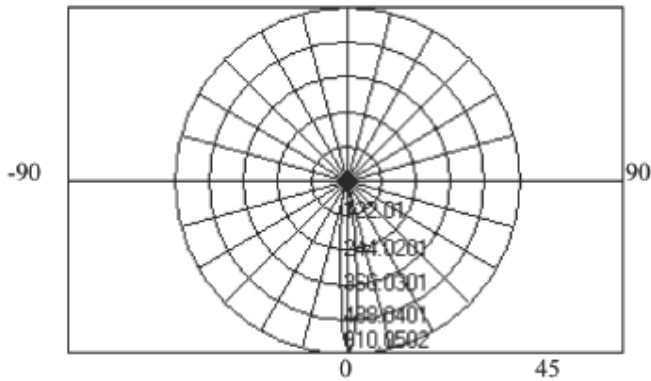

Light Distribution Curve C90/C270

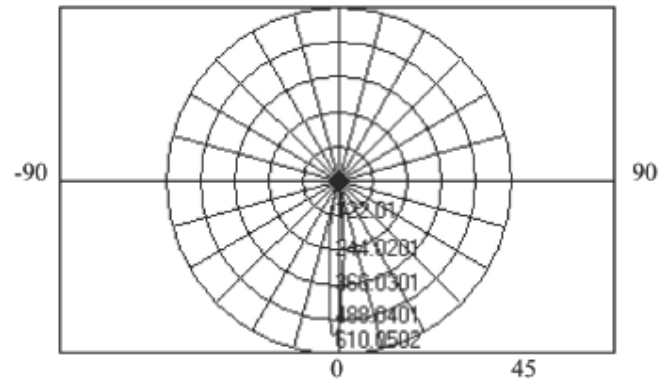

H[m]	Diameter[m]	Illuminance[lx]
0.60	0.10	1608.2
1.20	0.21	402.0
1.80	0.31	178.7
2.40	0.42	100.5
3.00	0.52	64.3

Half peak angle: 2 x 5.0° C0-C180

H[m]	Diameter[m]	Illuminance[lx]
0.60	0.10	1442.3
1.20	0.21	360.6
1.80	0.31	160.3
2.40	0.42	90.1
3.00	0.52	57.7

Half peak angle: 2 x 5.0° C90-C270

Add: 3F, HuShanRoad, No. 13, Daguangkan Industrial Zone, Bantian, LonggangDistrict, Shenzhen,

Guangdong, China

Tel: 86-755-84714721 Fax: 86-755-84714707

E-mail: qm@qmlighting.com

Website: www.qmlighting.com

Copyright© 2008 QM Lighting, Inc. All rights reserved.

version : 1.0



QM lighting

Illumination map

Iso-Lux[lx]

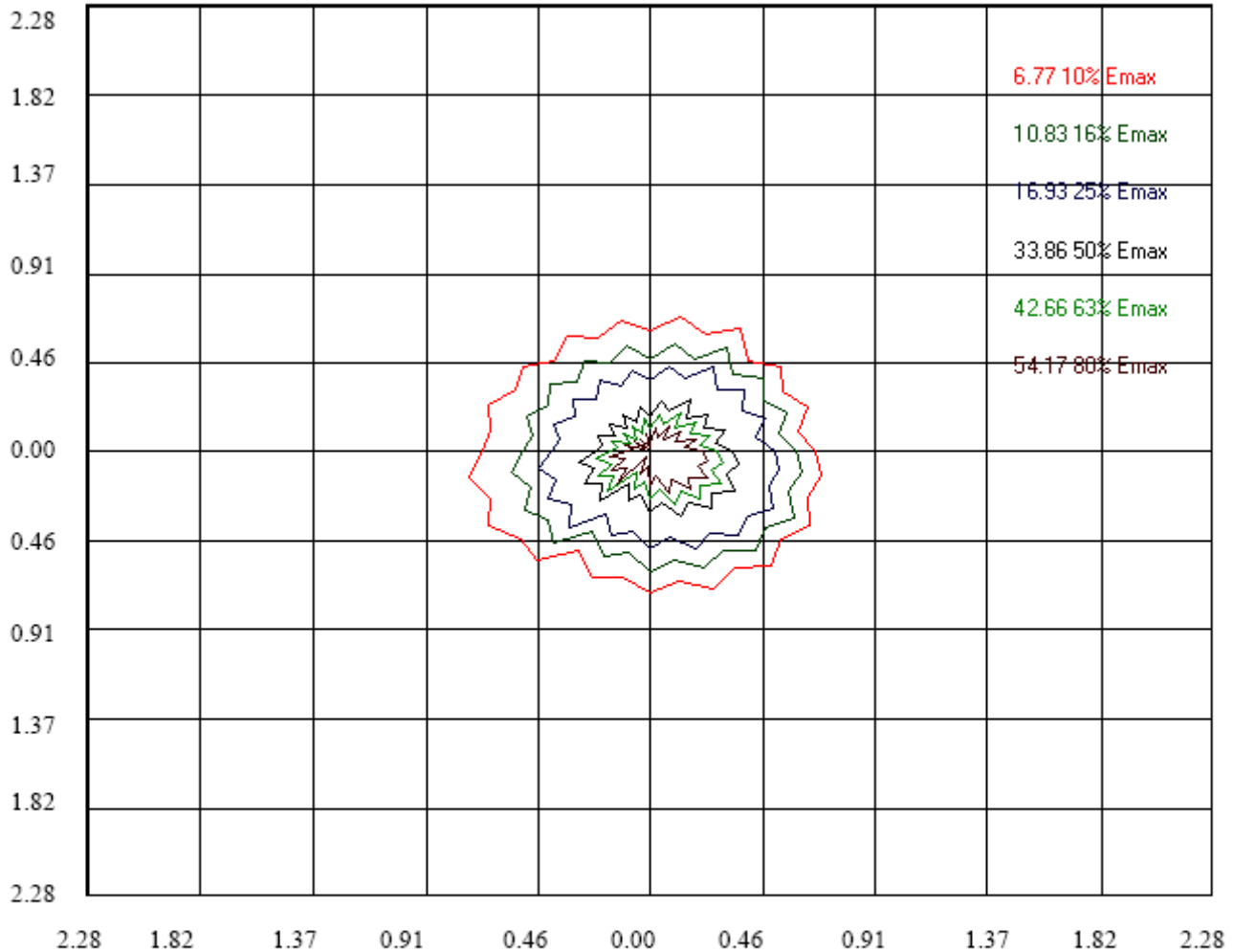

Height: 3 m

Max Illuminance: 67.716 lx

Add: 3F, HuShanRoad, No. 13, Daguangkan Industrial Zone, Bantian, LonggangDistrict, Shenzhen,

Guangdong, China

Tel: 86-755-84714721 Fax: 86-755-84714707

E-mail: qm@qmlighting.com

Website: www.qmlighting.com

Copyright© 2008 QM Lighting, Inc. All rights reserved.

version : 1.0



QM lighting

Package Information

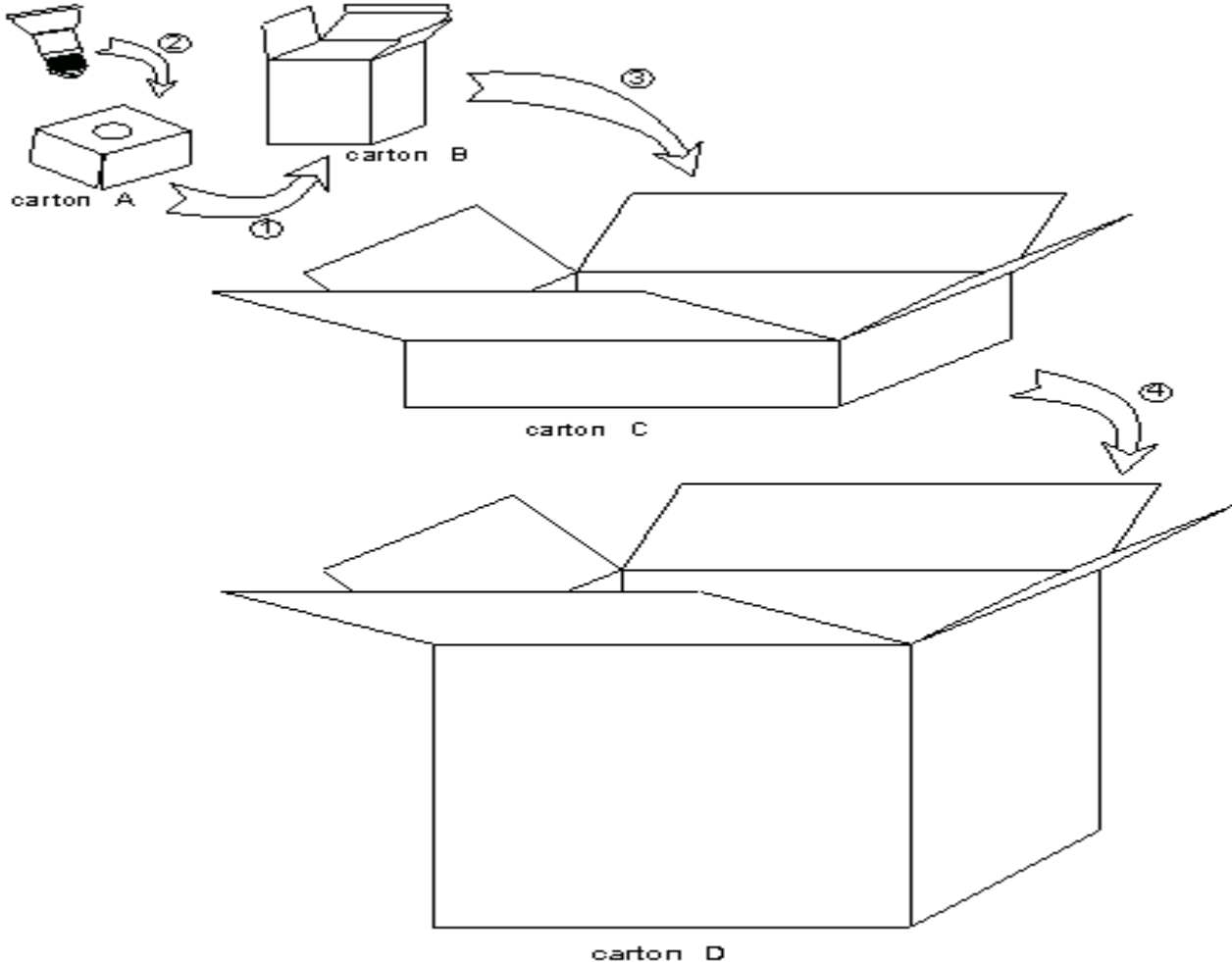

- Packing Notice:
1. Qty/ctn: 100pcs
 2. Gross Weight: 8.0kg
 3. Size of carton: 31X25X44CM
 4. Handle with care

Add: 3F, HuShanRoad, No. 13, Daguangkan Industrial Zone, Bantian, LonggangDistrict, Shenzhen,

Guangdong, China

Tel: 86-755-84714721 Fax: 86-755-84714707

E-mail: qm@qmlighting.com

Website: www.qmlighting.com

Copyright© 2008 QM Lighting, Inc. All rights reserved.

version : 1.0